

Wilfley

**Centrifugal
Acid
Pump**

**AG Fluoropolymer and
W-30 Plastic Pumps
Special Assembly**

Model AG



WILFLEY

Assembly procedure for AG Fluoropolymer and W-30 plastic pumps with threadless caseplate design. These instructions replace those on page 9 section 5 in the AG Operating Handbook.

1. Lubricate the O.D. of the stationary seal ring (Item 35) and press into the bore of the stationary seal ring housing (Item 39). If a press is not available use a block of wood and tap in place applying equal pressure across the surface.

2. Insert the rotary seal housing (Item 34) through the stationary seal ring housing (Item 39) so that the rotary seal housing (Item 34) seats properly in the counterbore of the stationary seal ring. (Item 35)

3. Screw the actuator body (Item 43) to the end of the rotary seal ring housing (Item 34) that protrudes through the stationary seal ring housing (Item 34). Screw together firmly by hand.

4. Carefully insert the governor spring (Item 42) inside the rotary seal housing (Item 34) and rotary seal housing (the white teflon V-cup seal Item 36) so as not to damage the seal lips. Lubricate the seal O.D. to aid installation.

5. Place the case plate assembly over the shaft and position against the frame.

6. Install expeller o-ring. (Item 46) Lubricate expeller hub and install expeller (Item 33) over the shaft, centering the hub into the rotary seal housing seal (Item 36). Start the hub into the seal but do not force it.

7. Install case plate (Item 32) into stationary seal housing (Item 39).

8. Install impeller seal (Item 47) on expeller. (Item 33)

9. Lubricate shaft threads with antiseize compound and screw on impeller. (Item 48) As the impeller tightens the expeller will move back into the rotary seal housing until it bottoms against the governor sleeve. (Item 28) Tighten impeller hand tight.

10. Install case seal (Item 49) over shoulder of case plate. (Item 32)

11. Insert this assembly into the case (Item 50) and secure with (8) $\frac{3}{8}$ -16 x $1\frac{1}{2}$ capscrews (Item 51). Tighten in an alternating pattern.

12. Set clearances per page 10, section 6.

Parts List and Recommended Spare Parts

Item Number	Number Required	#7100	#7300	#7400	#7000	#7450	Description
		Shaft Assembly Kit	Case Plate Kit	Pump Gasket Kit	Spare Parts Kit	Wet End Gasket Kit	
1	1	1					Shaft
2	2	2			2		Rear Bearing
3	1	1					Rear Bearing Locknut
4	1	1					Clamp Ring
5	1	1			1		Front Bearing
6	1						Bearing Retainer Housing
7	4						Clamp Ring Lock Washer
8	4						Clamp Ring Cap Screw
9	1			1			Bearing Retainer Housing Oil Seal
11	1						Frame
12	1			1			Frame O-Ring (2-157)*
13	4						Bearing Retainer Housing Cap Screw
14	4						Bearing Retainer Housing Cap Screw Lock Washer
17	1			1			Front Bearing Oil Seal
21	1						Sight Gauge
22	1						Oil Filler Plug
23	1						Closure Plate (not illustrated)
24	1						Oil Drain Plug
25	1						Oil Lubrication Plate (not illustrated)
26	1						Serial Number Plate (not illustrated)
27	12						Plate Drive Screw (not illustrated)
28	1						Governor Sleeve
29	1			1			Governor Sleeve O-Ring
30	2						Governor Weight
31	2						Governor Weight Pin
32	1		1		1		Rear Case Plate
33	1		1		1		Expeller
34	1		1		2		Rotary Seal Housing
35	1		1		2		Stationary Seal Ring
36	1		1	1		1	Rotary Seal Housing Seal
39	1		1		1		Stationary Seal Ring Housing
42	1		1		1		Governor Spring
43	1		1				Actuator Body
46	1			1		1	Expeller O-Ring
47	1			1		1	Impeller Seal
48	1				1		Impeller
49	1			1		1	Case Seal
50	1						Case Assembly
51	8						Case Cap Screw
52	1						Rotation Plate (not illustrated)
54	1				1		Bearing Retainer Housing Shim (Set)
63	1						Drain Hose (not illustrated)
64	1						Drain Hose Clamp (not illustrated)
65	1						Stationary Seal Housing Drain Nipple (not illustrated)

Parts are listed in approximate order of assembly sequence.

Model AG Fluoropolymer and W-30 Plastic Pumps

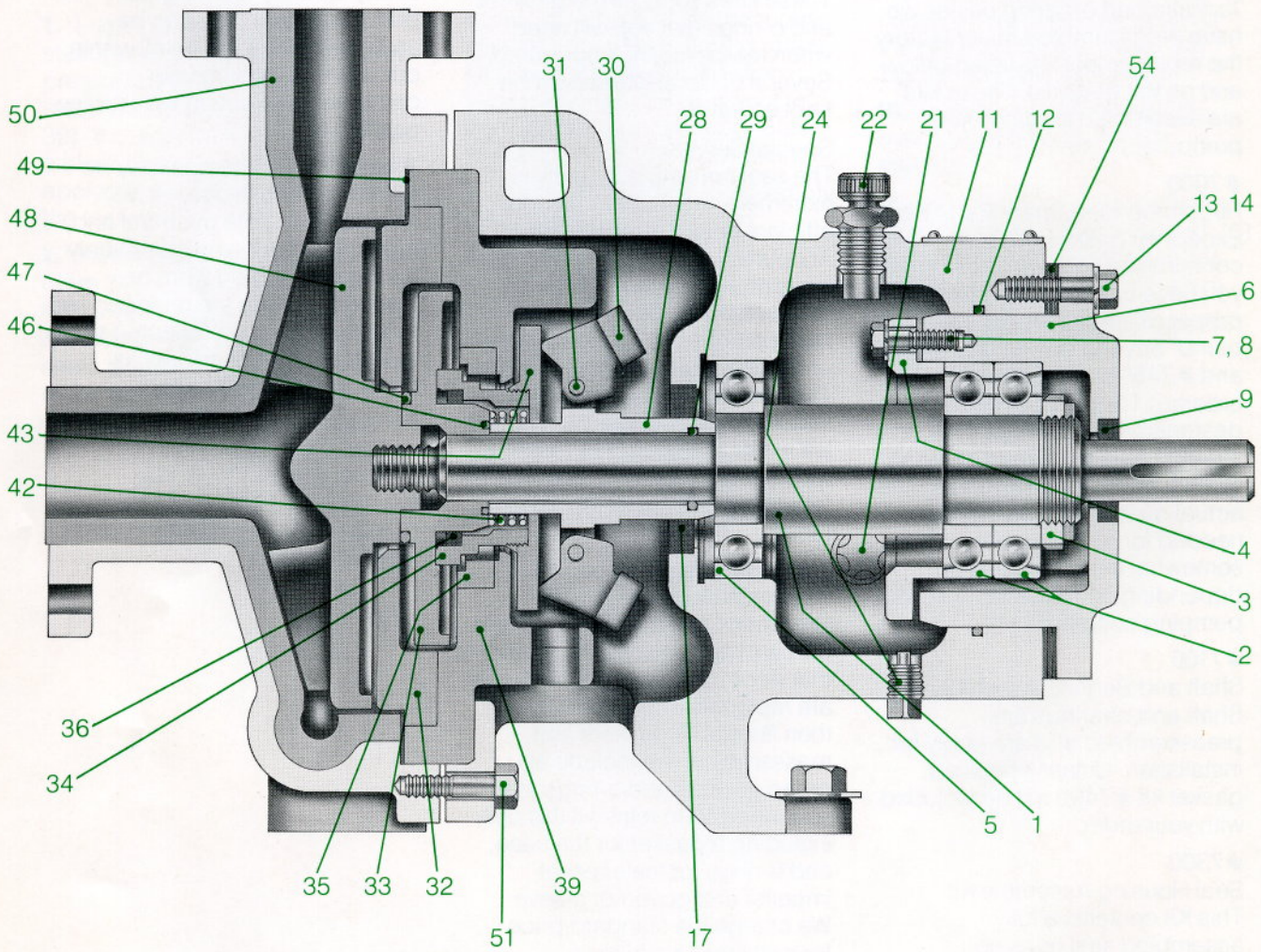

Spare Parts Ordering

Please include the serial number of your pump when ordering spare parts. With this number we can determine and duplicate the original configuration and materials of construction of your pump.

To make part ordering easier, we have preassembled in our factory the replacement kits listed below and on the parts list. These kits are assembled to match your pump.

#7000

Recommended Spare Parts Kit: Except for gaskets, this kit contains the parts we recommend you have on hand to provide proper maintenance for your pump. Several gasket kits, #7400 and #7450 should also be ordered. The spare parts kit is designed for one pump and should be altered when ordering stock for two or more pumps. The actual quantity of spare parts needed for a safe stock can be somewhat more or less than depending on the severity of your pumping conditions.

#7100

Shaft and Bearing Assembly Kit: Shaft and bearings are preassembled and are ready for installation. Unless specified, gasket kit #7400 will be included with your order.

#7300

Seal Housing Assembly Kit: This Kit contains a fully assembled seal housing assembly, the unit needs only to be installed in your pump. Unless specified, gasket kit #7450 will be included with the kit.

#7400

Gasket and O-Ring Kit:
(Entire pump)

#7450

Gasket and O-Ring Kit:
(Wetted end only)

These kits supply all the gaskets and o-rings that you will need when reassembling your pump. Several of these kits should be kept on hand.

Special Service

The seal housing assembly is extremely important to the total, efficient operation of the Wilfley AG pumps. Its parts, gaskets and seals must be in good working order. Many times parts are replaced unnecessarily due to the unfamiliarity with the assembly. The reverse is also true, parts that should be replaced are at times left in the assembly. For these reasons we provide the service of rebuilding this assembly in our factory.

Each assembly is thoroughly inspected upon arrival. The tolerances and condition of each part is checked and only the parts that don't meet test requirements are replaced. The assembly is then fitted with gaskets and reassembled. We include all pump gaskets and o-rings that you will need to reinstall this unit, including a gasket for the case, and o-rings for the expeller, impeller and governor sleeve. We charge the standard price for parts and a minimal reassembly fee.

The utilization of this service provides you with almost instantaneous pump seal housing assembly repair at an economical price. The units are overhauled and returned to you quickly.

Wilfley provides a special carton for easy mailing. You simply stock this assembly as a single spare part and let us do the rebuilding.

Please contact A. R. Wilfley and Sons or any of our representatives at any time, concerning our pumps or parts. You can be assured that we will do all within our power to ensure your complete satisfaction with Wilfley products.

Your Wilfley AG pumps may be returned to the factory, at any time, for complete overhaul and repair. Each pump is completely disassembled and worn or inoperable parts are replaced. All rebuilt pumps are subjected to the same testing procedures as newly constructed units.

For additional information and ordering parts contact:
A. R. Wilfley and Sons, Inc.
P.O. Box 2330
Denver, Colorado 80201
1-303-779-1777



A. R. Wilfley and Sons, Inc./P.O. Box 2330/Denver, Colorado 80201/303-779-1777

AGPSA1



A. R. Wilfley and Sons, Inc./P.O. Box 2330/Denver, Colorado 80201/303-779-1777

GPSA1